

# AUTONOMOUS WALKING MACHINES: MOTION PLANNING USING SENSORY INFORMATION

Teresa Zielinska<sup>a,b</sup>, John Heng<sup>a</sup>,

<sup>a</sup>NTU, School of Mechanical & Production Engineering, Singapore

<sup>b</sup>Warsaw Univ. of Technology, Poland

## Abstract

Current work on the motion planning of a Hexapod walking machine design is described here. The control system has a multi-processor architecture and research is conducted on hardware design structure as well as software functional decomposition. An inter-process cooperation between the processes utilizing client-server relation is employed. A motion generator is implemented that transforms motion commands into body position and leg trajectories. Finally, motion planning using sensory information and results are described and presented here.

Keywords: Walking machines, Legged machines motion planning, QNX, obstacle identification

## 1 Introduction

The walking machine is defined as a “technical device designed to perform functions similar to the locomotion of animals.” The locomotion of the machine is of the discrete type and may be performed using one, two, three, four, six, eight and more legs/pedipulators – to walk, run, or jump over a hard surface” [1]. Research on walking machines has shown rapid development in recent years, owing large part to the introduction of new generations of computers. Without a computer and an adequate sensory system, fast coordination of legs and body motion and efficient avoiding of obstacles will be impossible. Our goal is to develop six legged small, autonomous walking machine – Fig.1.

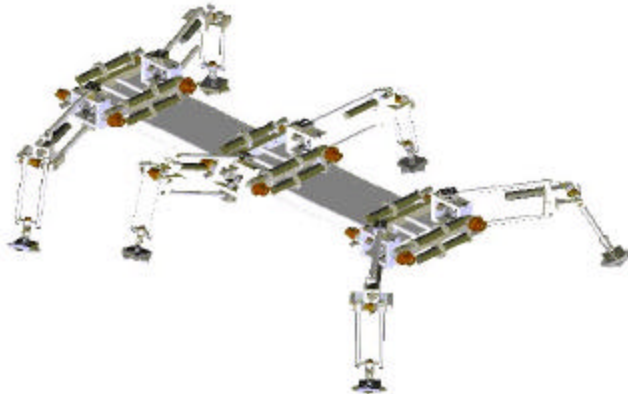

Fig.1. Design scheme of walking machine

## 2 Design Of Control System

The advantage of hexapods is that they use simple control rules (i.e. stability, terrain adaptation). Our ongoing research into hexapods includes the practical design and theoretical study [2,3,4,5]. One of the current issues involves the problem with regard to the optimum multi-processor control [3,4]. Another issue is on the design of hardware structure as well the software functional decomposition. The real time QNX system and Watcom C are being used in the development of the control software. Inter-process cooperation has a typical client-server relation. Currently these three processes have been developed into software: leg process, driver process and sensor process. The Leg process is the client while both the sensor and driver processes are the servers. The leg process is responsible for the generation of motion trajectories according to the rules given by the programmer and the data received from sensor process, which reads the data delivered by force sensor. The Driver process is responsible for the co-operation with hardware. It receives the both the data and commands from the leg process, transforms that data to the format acceptable by hardware (motion controllers) and communicates with the hardware. On the back-paths (from servers to clients) includes the transmission of the send-only sensor data (from sensor process), the confirmation of the movement done (from driver process) and the information about the errors which can be hardware or software type. The main frame of the applied QNX client-server inter-process cooperation is given in TABLE 1. That generator enables different body trajectories to be generated by using the special programming language which is very simple and which was defined by the authors of motion generator.

## 3 Motion Generator

Motion generator/simulator is implemented in Visual C. Its function is to transform the motion commands, which are written in defined language to the body position and leg trajectories which results in the reference trajectory following movement. Fig.2 shows the screen view of the motion simulator, the top view of the terrain and body trajectories are shown, The arrows mark the body motion history. Moreover, the enlarged view of the body with the

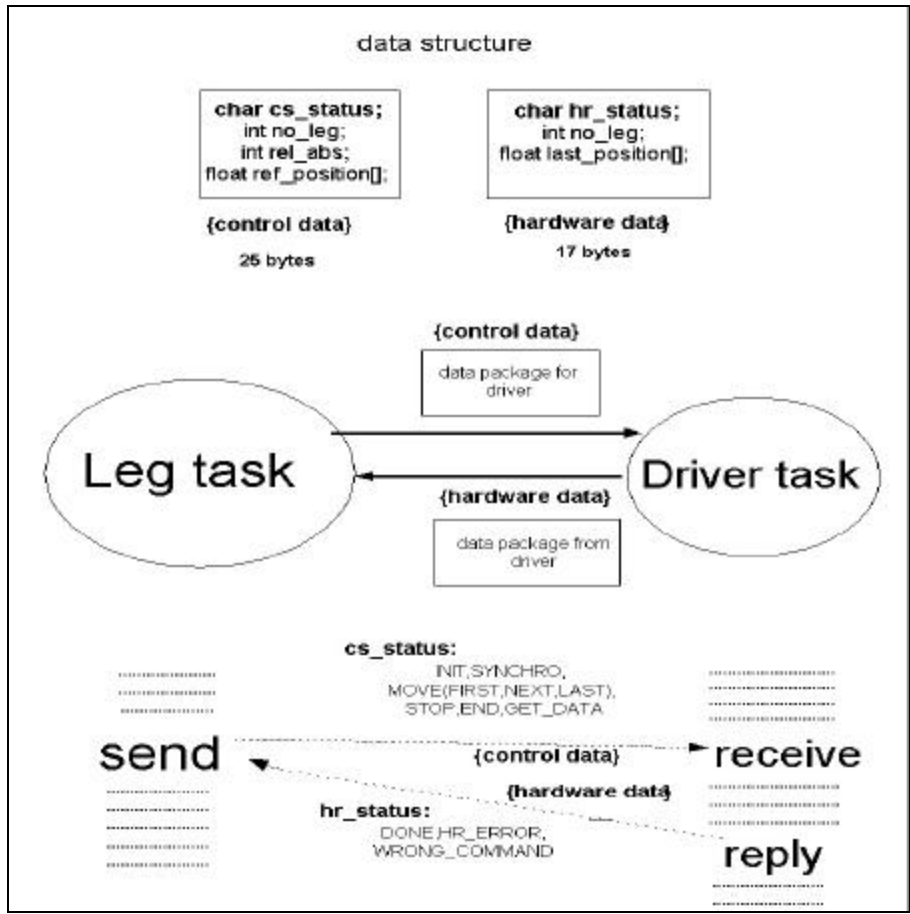

TABLE 1

legs is displayed for every moment of simulation time. The figure inset in the bottom left corner is the final screen view that shows the final body and leg positions when the body trajectory was completed. The simulator will form part of the motion generator that is to be used in the real control system in future.

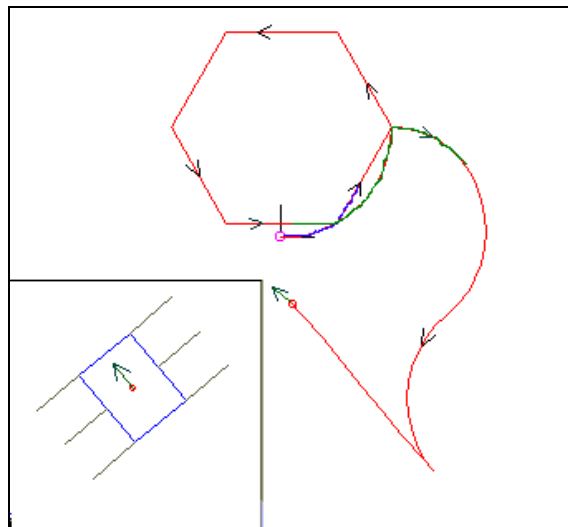

Fig.2. Motion simulator

#### 4 Motion Planning Using Sensory Information

Another theoretical study includes the development of the environment exploration strategy using sensory information. One crucial problem involves obstacle recognition and motion planning using external sensor information (about current walking machine – environment interaction). In the current design, the contact (touch) sensors on the leg-ends and ultrasonic range-finder were considered. Ultrasonic-range finders mounted on the leg-ends and oriented horizontally will be used to detect the distance to the obstacles. They will play a crucial role in the adaptive leg motion planning, coordinated by a sophisticated free gait algorithm, that attempt to overcome small obstacles.

The behavioral method of free gait planning utilizing the biological hypothesis of a two-stage motion planning (as in the human brain) will be adapted for that purpose [2]. It was assumed that ultrasonic range finders would be used for obstacle detection. The experimental tests for ultrasonic sensors were done, figure 3 shows the angular range in horizontal plane of POLAROID sonar in relation to the distance of obstacle (every point is an average value of 30 measurements). The decrease of the angular range in relation of the distance to the obstacle is

typical of sonar. The recorded data (fig.3) is put into consideration with regard to the design of number of sensors and their localization across the walking machine body. From the data given, the assumption of sensor sensitivity for obstacles located not further than 0.25 m decreases the number of sensors needed and simplifies the control software responsible for sensory information. For the longer range (about 2m) the number of sensors must be increased by at least two times. The final choice of the expected range of sonar's (and the quantity) will be related to the obtained speed and reaction time (ability of avoiding obstacles) of the walking machine. For the proper design of sensory equipment analysis of sensor range in vertical plane is also important.

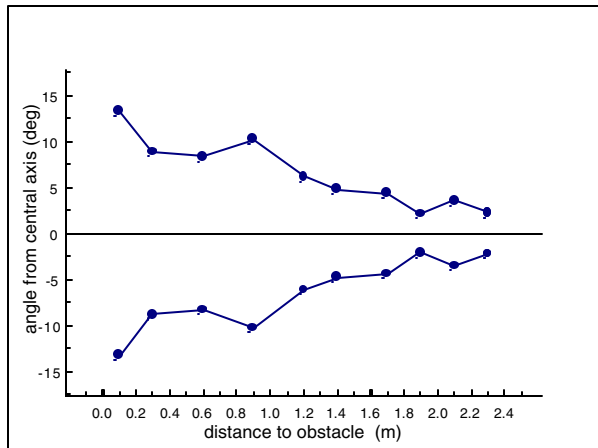

Fig.3. Angular range of ultrasonic sensor

Fig.4 shows the vertical cut of ultrasonic sensor beam within the range of 1.5m from the sensor. The sensor range across verticals is about two times smaller than the range in horizontal planes. Those features must be considered as the sensors are dedicated not only for the detection of the distance to the obstacles but also for the recognition of sizes of the obstacles [6].

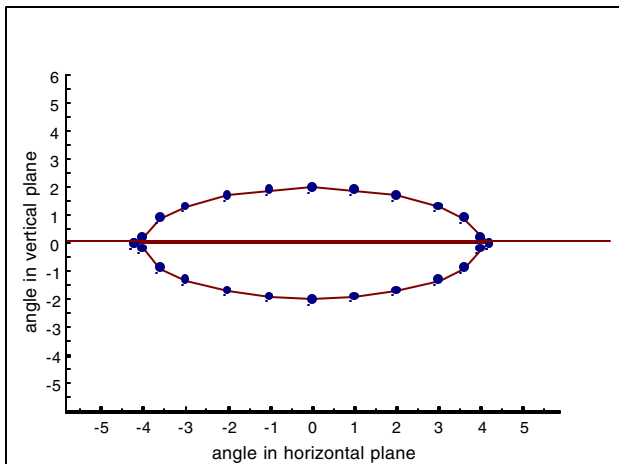
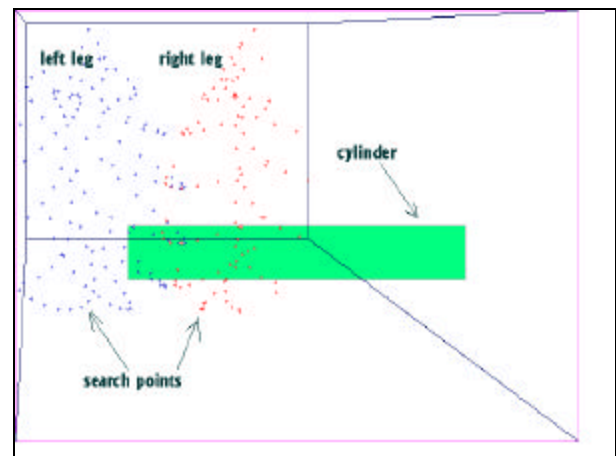

Fig.4. The vertical cut of ultrasonic sensor beam within the range of 1.5m from the sensor.

Utilization of ultrasonic sensors for the detection of the shape of obstacles is limited by their accuracy [6]. It was assumed that the walking machine being built will be utilized for exploration i.e. for exact recognition of objects located in front of the body, which are bigger than the size of obstacles which the leg-ends can avoidable.

For that purpose the contact sensors on the leg-ends will be used as the probes for obstacles shape and size recognition. That exploration task should be done as fast as possible but the collected data about the obstacle size and shape must be accurate. Fig.5.a shows the front-legs obstacle search points. Fig.5.b shows the results of exploration – the cylinder was found and their geometrical parameters were calculated based on the legs touch information. The software elaborated for that purpose provides the legs motion strategy for several different obstacle shapes as well to identify whether if the obstacle exist within the workspace of the legs.



a)

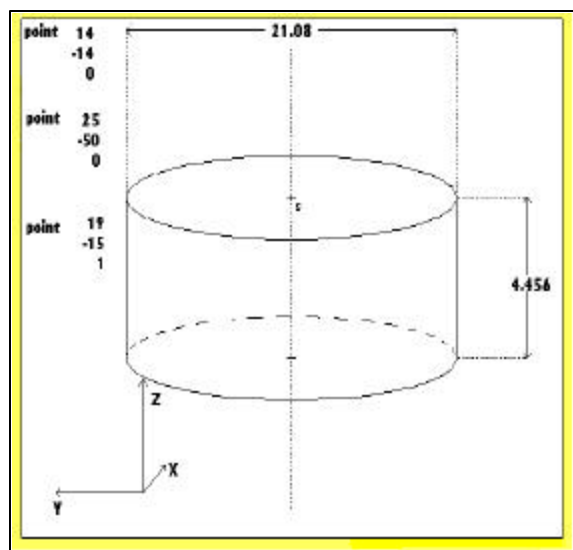

b)

Fig.5. Obstacle identification: a) front legs search points, b) result of identification

## 5 Conclusion

The development and usability of walking machines can be constantly improved by the aid of proper design. The final goal of this presented work is to develop autonomous walking machine, which will be optimal from the point of view of energy consumption and will be able to operate autonomously in natural conditions. The main assumption used for the design of control system considering the problem of environment recognition using sensors are shown in this paper. The current research focuses on the synthesis of control software and experimental tests of walking behavior.

## 6 References

- [1] Zielinska T: Walking Machines. In monograph Basics of Robotics: Theory and Composition of Manipulators and Robots. CISM Courses and Lectures no.402. SpringerVerlag 1999.
- [2] Zielinska T: Utilisation of biological patterns in reference trajectories generation of walking machines. IEEE 8<sup>th</sup> Int. Conference on Advanced Robotics. Workshop II: New Approaches on Dynamics Walking and Climbing Machines. Monterey. California, USA, 1997, pp.92-104
- [3] Zielinska T, Heng J., Seet G.: Walking machine position and force control Proc. of the IEEE . 1<sup>st</sup> Workshop on Robot Motion and Control. Poland 199, pp.141-145.
- [4] Zielinska T., Goh T., Seet G., Choong Kwong Chong: Synthesis of motion of autonomous hexapod. Automation'99 –Conf. On Automatic Control. Warsaw, Poland, 1999, pp.165-170
- [5] Heng J., Zielinska T., Shaoping Bai, Debao Zhou: Developmental work on a legged machine dedicated for pick and place tasks. 3<sup>rd</sup> Int. Conf on Industrial Automation. Canada - IAIA, 1999, pp.11.12-11.19
- [6] Zielinska T., Szabelak P.: Grasp planning of the objects recognised by the ultrasonic range finder. J. Measurements, Automatic Control and Robotics, no.7-8, 1998, pp.21-24 (in polish).